

**SPECIFICATION &
INSTALLATION GUIDE**



ROOFING & PROFILES (FIJI) LTD

COLORSTEEL

Colorbond

COLORCLAD™

Zincalume

GALVSTEEL™

info@roofingandprofiles.com.fj

www.roofingandprofiles.com.fj

CONTENTS

Introduction	1		
Quality of Installation	1		
Environmental Categories and Product Recommendations for the Pacific	2-3		
Recommended Roofing and Cladding Warranty Guide	4		
Recommended Maintenance Guide	5		
Animal Shelters	6		
Caring for our Products – A Quick Guide	6		
Colour Matching Paint	7		
Commercial Warranties	7		
Corrosion	8		
Corrosion Protection	9		
Drinking Water	9		
Edge Sealing of COLORBOND® ULTRA™	9		
Expansion Allowance and Temperature	10		
Field Painting	11		
Fixings and Fasteners	11		
Flashing Materials	12		
Flues – Domestic/Industrial	13		
Foot Traffic on Roofs	13		
Fume Extractors and Vents	14		
Gutters, Additions and Alterations	15-16		
Handling	17		
Joining, Sealing and Lap Priming	17		
		Maintenance	18
		Marking, Cutting and Drilling	19
		Mixing of Brands	19
		Mixing Products on a Roof	19
		Overpainting COLORBOND® Prepainted Steel Products	20
		Processing Plants	20
		Product Suitability	20
		Profile Bend Diameters – Roofing, Wall Cladding and Accessories	20
		Profile Design Information	21
		Quality Accreditation	21
		Roof Pitch Requirements	21
		Roof Fixing for Cyclone Areas	22
		Recommended Fastener Selection for Cyclone Areas	23
		Solar Heating Panels or Rubber Mats	24
		Storage	24
		Swarf Staining of Steel Roofing & Cladding	25-26
		Unwashed Areas	27
		UV Protection	27
		Water Ponding	28
		Weathering of COLORBOND® Prepainted Steel Products	28

INTRODUCTION

The key information sections in this guide have been designed alphabetically to detail the correct specification and installation of COLORBOND® prepainted steel, ZINCALUME® steel and GALVSTEEL™ material.

 Specification  Installation  Important

For quick and easy reference, each section is marked with a blue Specification icon and/or green Installation icon or red Important icon to indicate to the reader the applicability and importance of each information section.

Colorbond®

COLORBOND® prepainted steel describes those steel building materials which have oven-cured paint applied to a galvanised or ZINCALUME® steel base on a continuous 'coil to coil' operation.

The prepainting process gives excellent adhesion of the coating to the substrate, allowing rollforming to be performed after painting without delamination or deterioration of the paint film.

A variety of COLORBOND® prepainted steel coating types is offered. All COLORBOND® products are produced using either a ZINCALUME® steel substrate with an AZ150 or AZ200 coating class, (i.e.: 150 g/m² or 200 g/m² of zinc/aluminium alloy).

Data sheets on each of the COLORBOND® prepainted steel coating types may be obtained from New Zealand Steel Limited or any stockists of COLORBOND® prepainted steel.

Colorbond Ultra™

COLORBOND® Ultra™ products have an AZ200 Zincalume® coated steel base. This product is intended for Very Severe Marine environments. **COLORBOND® Ultra™ incorporates the latest, new, high durability, Super Polyester paint coating technology together with special anti corrosive primer.**

Colorbond XRW™

COLORBOND® XRW™ products have an AZ150 ZINCALUME® coated steel base. This product is intended for Severe to Moderate Inland environments. **COLORBOND® XRW™ incorporates Super Polyester technology, selected for its ability to provide optimum performance, durability and appeal.**

COLORCLAD™

COLORCLAD™ prepainted steel has a ZINCALUME® coated steel base and is available in a range of unique, fashionable, bold colours developed specifically for the Cladding market where developers or Corporate companies require a special look or appeal. **These colours incorporate leading edge technology in the paint formulations aimed at providing high durability and excellent colour retention as well as excellent anti corrosive characteristics in a cladding application.**

COLORSTEEL® Endura™

COLORSTEEL® ENDURA™ prepainted steel has a ZINCALUME® coated steel base and is available in a range of supplementary Pacific colours, selected for their ability to provide optimum performance, durability and appeal.

Zincalume®

ZINCALUME® zinc/aluminium alloy-coated steel has a 45% zinc, 55% aluminium, alloy coating which offers superior corrosion resistance compared to galvanised steel in most environments (particularly coastal environments).

ZINCALUME® steel and the substrate used to produce COLORBOND® prepainted steel products, conform to AS1397:2001.

GALVSTEEL™

Traditional galvanised steel is offered under the trade name of GALVSTEEL™. This material has a 100% zinc coating and is available in a range of dimensions, grades, zinc coating weights and types.

QUALITY OF INSTALLATION

New Zealand Steel Limited takes a great deal of pride in manufacturing these top quality products and knows that the final appearance is influenced by the skills and care taken with the material. The reputation of both the fixer and the product is enhanced by quality workmanship.

ROOFING & PROFILES (FIJI) LTD
info@roofingandprofiles.com.fj
www.roofingandprofiles.com.fj

ENVIRONMENTAL CATEGORIES AND PRODUCT RECOMMENDATIONS

INTRODUCTION

The Pacific Islands have a wide range of environmental conditions, from the harsh open surf beaches, to the relative shelter of the inland valleys. Therefore, New Zealand Steel Limited offers a range of premium painted steel products which are suitable for most locations.

MODERATE INLAND – ISO CATEGORY C

Characterised by:

- No obvious marine or industrial influences.
- Typically more than 1000 metres from the exposed coasts or more than 500 metres from industrial emissions.

MODERATE COASTAL – ISO CATEGORY C

Characterised by:

- Little or no salt deposits.
- The occasional smell of salt in the air.
- Typically 500-1000 metres from breaking surf such as is found on exposed coasts, OR
- In the immediate vicinity of calm salt water such as estuaries.

SEVERE – ISO CATEGORY D

Characterised by:

- Light salt deposits.
- A frequent smell of salt in the air.
- Typically 200-500 metres from breaking surf such as is found on exposed coasts.
- In the immediate vicinity of large expanses of calm salt water such as harbour foreshores.

This environment may be extended inland by prevailing winds and local conditions.



500m+

200m

50m

Colorbond®

COLORBOND® ULTRA™

COLORBOND® ULTRA™

COLORBOND® ULTRA™

COLORBOND® XRW™

COLORBOND® XRW™

COLORCLAD™

COLORCLAD™

COLORCLAD™

COLORSTEEL®

COLORSTEEL® ENDURA™

COLORSTEEL® ENDURA™

Zincalume®

ZINCALUME®

ROOFING & PROFILES (FIJI) LTD

info@roofingandprofiles.com.fj

www.roofingandprofiles.com.fj

VERY SEVERE – ISO CATEGORY E

Characterised by:

- Heavy salt deposits.
- The almost constant smell of salt spray in the air.
- Close to breaking surf (typically 50-200 metres) such as is found on exposed coasts.

This environment may be extended inland by prevailing winds and local conditions.

SEVERE INDUSTRIAL AND URBAN ENVIRONMENTS



IMPORTANT

- As product use is dictated by local conditions, seek advice from your roofing supplier for the best New Zealand Steel Limited product to suit your specific environment. info@roofingandprofiles.com.fj
- Gutters should be installed according to manufacturer's instructions. www.roofingandprofiles.com.fj
- Unwashed and high risk areas – manual washing every 8 months.



RECOMMENDED ROOFING AND CLADDING WARRANTY GUIDE

COLORBOND® ULTRA™

COLORBOND® XRW™

Also COLORSTEEL® ENDURA™

COLORCLAD™

VERY SEVERE – ISO CATEGORY E

50m from high water and characterised by:

- Heavy salt deposits.
- Almost constant smell of salt spray in the air.
- Typically 50m from breaking surf such as is found on exposed coasts.

This environment may be extended inland by prevailing winds and local conditions.

10 years: covering the paint surface against flaking and peeling.

12 years: against perforation as a result of corrosion.

Not recommended.

Not recommended.

SEVERE – ISO CATEGORY D

200m from high water and characterised by:

- Light salt deposits.
- A frequent smell of salt in the air.
- Typically 200m from breaking surf such as is found on exposed coasts.
- In the immediate vicinity of large expanses of calm salt water such as harbour foreshores.

This environment may be extended inland by prevailing winds and local conditions.

15 years: covering the paint surface against flaking and peeling.

15 years: against perforation as a result of corrosion.

10 years: covering the paint surface against flaking and peeling.

10 years: against perforation as a result of corrosion.

12 years: covering the paint surface against flaking and peeling.

12 years: against perforation as a result of corrosion.

MODERATE COASTAL – ISO CATEGORY C

500m from high water and characterised by:

- Little or no salt deposits.
- An occasional smell of salt in the air.
- Typically 500-1000m from breaking surf such as is found on exposed coasts, OR
- In the immediate vicinity of calm salt water such as estuaries.

This environment may be extended inland by prevailing winds and local conditions.

15 years: covering the paint surface against flaking and peeling.

20 years: against perforation as a result of corrosion.

10 years: covering the paint surface against flaking and peeling.

10 years: against perforation as a result of corrosion.

12 years: covering the paint surface against flaking and peeling.

12 years: against perforation as a result of corrosion.

Commercial warranties are issued through the Rollformer by New Zealand Steel Limited and the terms are specific to each contract.

In order to ensure the appropriate roofing products are specified for the intended service life in any given environment, New Zealand Steel recommends that approved Roll Formers are contacted and consulted as early as possible in the design stage to ensure correct material selection and backing by an appropriate product warranty.

Applications for Roofing Warranties will be assessed by the Roll Former and made directly to New Zealand Steel, based on the Roofing Warranty Guide outlined above after declaration and assessment of local environmental conditions.

Factors such as roof design, roof pitch, profile, coating type, internal and external environments and special conditions

(such as good design to ensure all eaves are covered and application of edge protection lacquer in very severe coastal areas) are all assessed at the time of the Warranty application. **Maintenance requirements as specified in this publication and on the Warranty document are an integral part of the Warranty conditions.**

A roofing Warranty is issued on the satisfactory completion of the building project or contract. Installation must be carried out in accordance with the Pacific Specification and Installation Guide and according to good trade practices.

A site inspection by the Rollformer on behalf of New Zealand Steel may be carried out prior to the issuing of any Warranty. The maintenance programme specified in the roofing Warranty must be carried out to validate the Warranty.

RECOMMENDED MAINTENANCE GUIDE

**COLORBOND®
ULTRA™**

**COLORBOND®
XRW™ and
COLORCLAD™**

ZINCALUME®

Also COLORSTEEL® ENDURA™

VERY SEVERE – ISO CATEGORY E

50m from high water and characterised by:

- Heavy salt deposits.
- Almost constant smell of salt spray in the air.
- Typically 50m from breaking surf such as is found on exposed coasts.

This environment may be extended inland by prevailing winds and local conditions.

Roofing
Wall Cladding

**Gutters
Downpipes
Fascia**

- Rain washing.
- Rain washing plus manual washing every 3 months.
- Manual washing every month.

Not recommended.

Not recommended.

SEVERE – ISO CATEGORY D

200m from high water and characterised by:

- Light salt deposits.
- A frequent smell of salt in the air.
- Typically 200m from breaking surf such as is found on exposed coasts.
- In the immediate vicinity of large expanses of calm salt water such as harbour foreshores.

This environment may be extended inland by prevailing winds and local conditions.

Roofing
Wall Cladding

**Gutters
Downpipes
Fascia**

- Rain washing.
- Rain washing plus manual washing every 6 months.
- Manual washing every 3 months.

- Rain washing.
- Rain washing plus manual washing every 6 months.
- Manual washing every 3 months.

Not recommended.

MODERATE COASTAL – ISO CATEGORY C

500m from high water and characterised by:

- Little or no salt deposits.
- An occasional smell of salt in the air.
- Typically 500-1000m from breaking surf such as is found on exposed coasts, OR
- In the immediate vicinity of calm salt water such as estuaries.

This environment may be extended inland by prevailing winds and local conditions.

Roofing
Wall Cladding

**Gutters
Downpipes
Fascia**

- Rain washing.
- Rain washing plus manual washing every year.
- Manual washing every 6 months.

- Rain washing.
- Rain washing plus manual washing every year.
- Manual washing every 6 months.

- Rain washing.
- Rain washing plus manual washing every 6 months.
- Manual washing every 3 months.



ROOFING & PROFILES (FIJI) LTD
info@roofingandprofiles.com.fj
www.roofingandprofiles.com.fj



ANIMAL SHELTERS

Some agricultural applications may create internal environments in which the build-up of pollutants or fumes is a potential source of corrosion. A corrosive ammonia environment can develop within sheds used for intensive animal farming where ventilation is limited.

Design Guide:

1. Contact New Zealand Steel Limited for specialist advice.
2. ZINCALUME® STEEL OR COLORBOND® PRODUCTS SHOULD NOT BE USED IN THIS ENVIRONMENT DUE TO EXTREME CORROSION RISK.
3. GALVSTEEL™ products are recommended for this application.



CARING FOR OUR PRODUCTS – A QUICK GUIDE

Do

- Do check the delivery to make sure you have the right product, delivered in prime condition.
- Do arrange for suitable dry storage if the material is not going to be used immediately.
- Do ensure the appropriate fasteners are selected for the environment.
- Do cut with nibbler shears or snips.
- Do remove swarf from the job as the work progresses, or at least at the end of each day.
- Do wear clean, flat, rubber-soled footwear.
- Do lift sheets onto the job, rather than drag them.
- Do apply edge sealer on all cut edges of COLORBOND® ULTRA™ prepainted steel.

Don't

- Don't mix product or brands on a single job.
- Don't cut sheets with an abrasive disc cutter.
- Don't attempt to solder COLORBOND® and COLORSTEEL® prepainted steel or ZINCALUME® steel surfaces.
- Don't use lead-headed nails.
- Don't use touch-up paints.
- Don't leave off-cuts, swarf or other debris on the roof.
- Don't slide tools down the roof.
- Don't use lead flashings with ZINCALUME® steel or COLORBOND® and COLORSTEEL® prepainted steel products.
- Don't use with wet concrete.
- Don't store in an environment that allows moisture to pool between sheets.

! COLOUR MATCHING PAINT

Colour-matching paint must not be applied to COLORBOND® prepainted steel.

Air-dried paints will weather at a rate different from that of COLORBOND® prepainted steel products.

Minor scratches are best left alone. They become less evident as the coating weathers.

Widespread coating damage to any COLORBOND® prepainted steel product can only be rectified by replacement of the affected sheet.

Colour-matching paint may be used to paint roof accessories prior to installation.

Colour-matched fasteners are available.



! COMMERCIAL WARRANTIES

Commercial warranties are issued through the Rollformer by New Zealand Steel Limited and the terms are specific to each contract.

In order to ensure the appropriate product is specified for the intended service life in any given environment, New Zealand Steel Limited is keen to be consulted as early as possible in the design stage to ensure correct material selection and backing by an appropriate warranty.

Warranty applications are generally made through the roofing manufacturer and warranty periods and conditions are assessed by New Zealand Steel Limited.

Factors such as roof design, roof pitch, profile, coating type, internal and external environments and special conditions (such as requirement for “Clean in Place”) are all assessed at the time of the warranty application. Maintenance requirements will be specified as part of the warranty.

A warranty is issued on the satisfactory completion of the contract. Installation must be carried out in accordance with New Zealand Steel Limited’s requirements.

A site inspection by New Zealand Steel Limited, or an approved representative, may be carried out prior to the issuing of any warranty.

The maintenance programme specified in the warranty must be complied with to validate the warranty.

Note: Warranties are not offered on GALVSTEEL™ products.

ROOFING & PROFILES (FIJI) LTD
info@roofingandprofiles.com.fj
www.roofingandprofiles.com.fj



CORROSION

Dissimilar Metals Corrosion

When two different metals are in contact and moisture is present, one metal is relatively protected while the other suffers accelerated corrosion. This is known as galvanic or bi-metallic corrosion. A similar effect commonly occurs with water flowing over dissimilar metals.

This form of corrosion is commonly found:

1. Where water is discharged from copper or brass systems over GALVSTEEL™ or COLORBOND® prepainted steel or ZINCALUME® coated steel roof.
2. Where unpainted lead flashings are applied directly to ZINCALUME® coated steel products. (Refer to Flashing Materials, page 12).
3. Where fasteners are incompatible with the roofing material. (See Fixings and Fasteners, page 11)



Design Guide:

1. Separate dissimilar metals by using a barrier such as PVC tape, neutral cure silicone sealant or an appropriate paint system.
2. Prevent potential run-off from copper or brass pipes over GALVSTEEL™, ZINCALUME® coated steel or COLORBOND® prepainted steel surfaces by diverting the discharge clear of the roofing.

Note: Coastal areas with high salt levels and high humidity will increase the possibility of dissimilar metals corrosion.

Compatibility

**ZINC
ZINCALUME®
ALUMINIUM**

STEEL

LEAD

COPPER

STAINLESS STEEL

More Active Metals



This chart lists commonly used metals in a “Galvanic Series”. If any of these metals are in damp contact or a run-off situation, the metal higher on the table will sacrifice itself to protect the metal lower on the scale.

Therefore the simple rule is to remember that you can run water down but not uphill. For example, zinc to copper is alright but copper to zinc is not.

ROOFING & PROFILES (FJI) LTD

info@roofingandprofiles.com.fj

www.roofingandprofiles.com.fj



CORROSION PROTECTION

The long established method of protecting steel against corrosion has been to apply a coating of zinc (galvanising). The zinc surface forms a hard, impervious layer which limits further corrosion. This provides for the longevity of performance which we have come to expect from galvanised steel products.

The zinc coating also possesses another very useful property. Small exposed surfaces of the underlying steel such as scratches or cut edges do not corrode because of an effect known as sacrificial protection.

ZINCALUME® steel, a zinc/aluminium alloy coating, provides a superior performance to that of galvanised steel. It combines the barrier protection of aluminium and the sacrificial protection of zinc, thus giving the best of both worlds.

It follows that by coating these substrates with an added paint system, the steel core will be protected for a longer period. It is for this reason that the COLORBOND® prepainted steel coating systems were developed. Each coating is designed to protect the substrate from specific environmental conditions.

Upper Cross Section of COLORBOND® Coated Steel

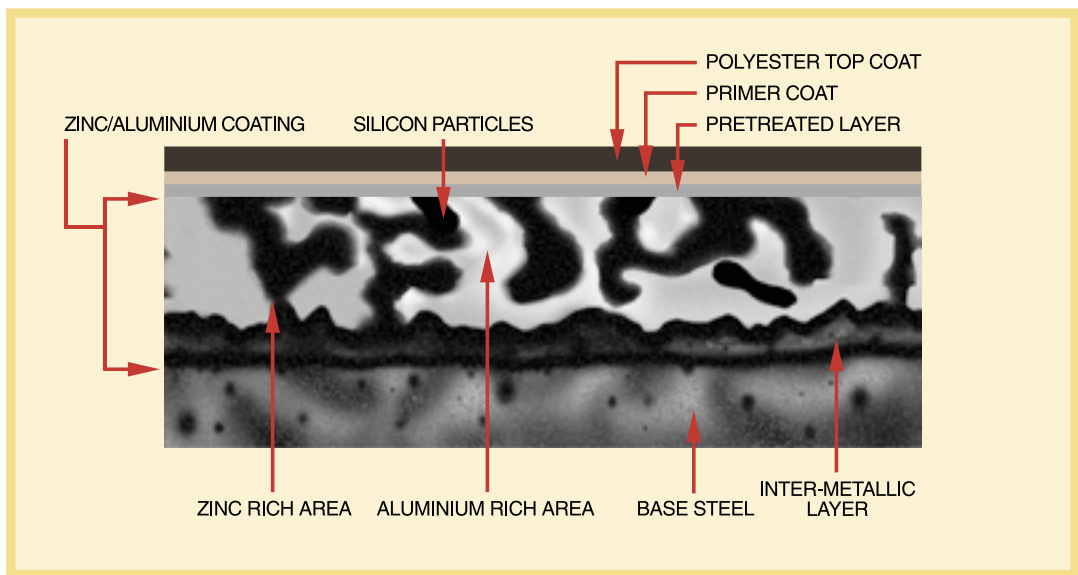

DRINKING WATER

Rainwater collected from roofs clad with products made from GALVSTEEL™, ZINCALUME® coated steel and COLORBOND® prepainted steel, is suitable for collecting drinking water, provided the water is not contaminated from other sources.

The first 25mm of rainfall from a newly installed roof must be discarded before drinking water collection starts.

Where a post painted paint system is applied to the roof, its suitability for the collection of drinking water must be established.



EDGE SEALING OF COLORBOND® ULTRA™

COLORBOND® ULTRA™ product is designed for Very Severe Environments and its performance relies on maintaining the integrity of the coating. Where COLORBOND® ULTRA™ product is cut, the cut edge must be sealed. All cut edges of sheets and accessories such as ridging, flashings and guttering should also be sealed.

Design Guide:

1. A coat of 'Cut Edge Protection Lacquer' should be applied using a brush or a foam roller.
2. Cut Edge Protection Lacquer is available from Akzo Nobel Coatings Ltd or your local rollforming supplier.
3. Failure to apply an approved edge sealer to cut edges will invalidate the warranty.

Stacks of sheets may be coated with the lacquer diluted 10% with water. There is less risk of sheets sticking together if sheets are treated this way.

ROOFING & PROFILES (PJ) LTD
info@roofingandprofiles.com.fj
www.roofingandprofiles.com.fj



EXPANSION ALLOWANCE AND TEMPERATURE

All roofing and cladding is subject to expansion and contraction due to temperature extremes. This is particularly evident with darker colours and long spans where the expansion may be as much as 9.0mm for a 10.0 metre sheet. Fixing systems must allow for expansion and accommodate the longitudinal movement which results.

Design Guide:

Typical Roof Temperatures	Summer Average	Calm Conditions
	INSULATED	UNINSULATED
Light Colours (e.g. Surf Mist)*	58°C	48°C
Medium Colours (e.g. Wilderness)	79°C	67°C
Dark Colours (e.g. Iron Bark)	92°C	77°C

Note: In the Pacific these temperatures may be exceeded.

*Light Colours include unpainted galvanised and ZINCALUME® steel material.

Typical Roof Expansions			
Based on 0.01mm/m/°C			
	8 METRE RUN	12 METRE RUN	18 METRE RUN
Light Colours*	5mm	7mm	11mm
Medium Colours	6mm	10mm	14mm
Dark Colours	7mm	11mm	17mm



ROOFING & PROFILES (FIJI) LTD
info@roofingandprofiles.com.fj
www.roofingandprofiles.com.fj

FIELD PAINTING

ZINCALUME® coated steel is readily paintable using good quality primers and water-based acrylic topcoats.

GALVSTEEL™ roofs can be painted immediately after installation, and to achieve optimum results, it is recommended that the painting be carried out within one to two months of installation. Apply a good quality acrylic galvanised iron primer and water-based acrylic topcoats.

Paint manufacturers' instructions should be followed.

Dirt, grease and any loose materials must be cleaned off so the surface is clean and dry prior to the first coat being applied.

FIXINGS AND FASTENERS

The selection of the appropriate form of fastener is a task which should not be solely influenced by cost. Fastener costs are minimal relative to the overall project and there is no benefit to be gained through the use of inferior fixings. The fastener durability should equal or exceed that of the roofing or cladding product.

Design Guide:

1. Fastener performance should conform with the requirements of AS3566 (and Amendments) "Screws – Self Drilling for the Building and Construction Industries".
2. Stainless steel and stainless steel capped fasteners are not recommended for use with ZINCALUME® coated steel or COLORBOND® prepainted steel products in all environments due to incompatibility.
3. Low carbon, non conducting sealing washers are required for use with COLORBOND® prepainted steel products and ZINCALUME® coated steel products.

The advice of specialist fastener manufacturers is readily available and these manufacturers should be consulted, particularly where COLORBOND® prepainted steel products are to be fixed in Very Severe or Severe Environments. (see Environmental Categories and Product Recommendations, pages 2 and 3).

4. Fasteners with heavy zinc or zinc-tin coatings or zinc alloy coated heads complying with AS3566 Class 3 and 4 are fully compatible with all products.
5. Fasteners used on COLORBOND® prepainted steel products should be factory coated to provide an accurate colour match with COLORBOND® prepainted finishes.

6. Rivets:

- Use aluminium rivets for joining all New Zealand Steel Limited coated products. (Ensure rivet is of a suitable strength for the purpose. Refer to your rivet supplier).
- Monel rivets are not recommended as they are incompatible due to their copper content.

Fastener Recommendations

Environmental Category*	ISO	ZINCALUME®	COLORCLAD™/ COLORSTEEL® ENDURA™	COLORBOND® XRW™	COLORBOND® ULTRA™
Coastal:					
Very Severe	Cat. E	NR	NR	NR	4
Severe	Cat. D	NR	4	4	4
Moderate	Cat. C	3,4	3,4	3,4	3,4
Industrial:					
Very Severe	Cat. E	NR	NR	NR	4
Severe	Cat. D	NR	4	4	4
Moderate	Cat. C	3,4	3,4	3,4	3,4
Inland:					
Moderate	Cat. C	3	3	3	3,4

NR: New Zealand Steel product not recommended for these Environmental Categories.

4: Heavy zinc or zinc-tin coatings or zinc alloy coated heads complying with AS3566.2-2002 Class 4.

3: Heavy zinc or zinc-tin coatings complying with AS3566.2-2002 Class 3.

* See pages 2 and 3 for definitions of Environmental Categories.



FLASHING MATERIALS

(Also refer to Corrosion)

Recommendation

Flashings and ridge capping should be manufactured from the same coating system as used for the main roof area to ensure equal durability. For COLORBOND® prepainted steel and ZINCALUME® steel products, extended ridge caps, soft zinc or practices such as cutting and notching are recommended.

Where penetration flashings are required, neoprene or silicone rubber, EPDM aluminium, aluminium edge, or soft zinc all give excellent performance.

For GALVSTEEL™ products, prepainted lead flashings can be used, as well as the above. Do not cut flashings or roofing accessories with high speed abrasive discs as this is likely to leave swarf contamination on a roof. Use nibbler or hand shears.

Compatibility

When two different metals are in contact and moisture is present, one metal is relatively protected while the other suffers accelerated corrosion. This is known as galvanic or bi-metallic corrosion. A similar problem commonly occurs with water flowing over dissimilar metals.

Copper

Copper is not compatible with GALVSTEEL™, ZINCALUME® steel or COLORBOND® prepainted steel products, especially where it is in contact with water or where water can flow from it. Every effort must be made to prevent the overflow of water from copper pipes on to the roofing and guttering material.

Lead

Lead is not compatible with ZINCALUME® steel products. Corrosion will result from contact between lead and ZINCALUME® steel material or from water run-off from lead to ZINCALUME® steel products.

For this reason New Zealand Steel Limited does not recommend the use of lead with ZINCALUME® steel or COLORBOND® prepainted steel.



■ ■ FLUES – DOMESTIC/INDUSTRIAL

Natural gas, wood, coal or oil-fired heaters generate high levels of sulphur compounds. When vented over a roof, particularly in damp conditions, sulphuric acid forms which will lead to premature corrosion of the roof, guttering and downpipes.

Design Guide:

1. Design the height of the flue to allow combustion by-products to be dissipated.
2. Specify a COLORBOND® prepainted steel product designed for very severe environments.
3. Ensure that heaters are run as efficiently as possible to allow complete combustion.
4. Regularly wash the roof to remove contaminants.

■ ■ FOOT TRAFFIC ON ROOFS

Repeated foot traffic and the dragging of maintenance or cleaning equipment, may damage the roof which will reduce its life expectancy.

Design Guide:

1. Design and install catwalks and platforms over the roof where necessary.
2. Aluminium or galvanised steel catwalks are recommended.
3. Design catwalks and platforms so as not to create an unwashed or ponding area on the roof.
4. Timber catwalks and platforms have the potential to cause corrosion on the underlying roof.





FUME EXTRACTORS AND VENTS

Corrosive dust and particles can be released through roof vents and discharged onto the roof surface. The immediate area of the roof adjacent to the vent is then at increased risk of corrosion.

Design Guide:

1. Install filter elements to contain hazardous material.
2. Specify a COLORBOND® prepainted steel product designed for very severe environments to be installed adjacent to the vent.
3. Consider applying a suitable protective coating to the affected area of the roof.
4. Maintain coal or oil fired boilers or incinerators so that they do not discharge high sulphur levels over the roof surface.
5. Regularly wash the roof to remove contaminants.



ROOFING & PROFILES (FIJI) LTD
info@roofingandprofiles.com.fj
www.roofingandprofiles.com.fj



GUTTERS, ADDITIONS AND ALTERATIONS

(Combining Different Roofing Systems)

Care should be taken when combining products on a roof system. If products are combined incorrectly, severe localised corrosion may occur as a result of 'inert catchment'.

What is inert catchment? (Design faults to avoid)

The collection of rainwater running into gutters is influenced by atmospheric conditions, industrial fallout and rainfall intensity and frequency. Acid rain, which is quite corrosive to metal, is a feature of industrial and heavily populated areas with fumes from motor vehicle exhausts. Rain near the coast can pick up chlorides from salt air depending on the turbulence of the surf prior to precipitation.

When acid rain falls on a large area of roof, it is collected and directed in concentrated streams into a small area of gutter/spouting. If there is any tendency for coatings on metals in the roofing system to be affected by water, it is more likely to occur here.

The condition which can arise to cause corrosion to occur in this way is for water to fall on roofs which do not affect the corrosive properties of rain in any way. Such a roof is called an 'inert catchment' and typical examples are glazed terracotta tiles, fibreglass, decking formed from aluminium, COLORBOND® prepainted steel and ZINCALUME® coated steel.

Roofs which alter the corrosive components of rain are unglazed cement tiles and unpainted zinc-coated materials. These actually counteract to some extent the acids and chlorides in rain so that by the time it reaches the guttering/spouting, it is far less reactive and the gutter will have a longer life.



Some examples of Inert Materials:

- ZINCALUME® steel • COLORBOND® prepainted steel • Glass • Fibreglass • Glazed Tiles
- PVC • Acrylic • Aluminium

To achieve maximum life from your rainwater goods, we recommend that they are manufactured from either ZINCALUME® coated steel or COLORBOND® prepainted steel products.

ZINCALUME® coated steel gutters will give a longer service life than traditional galvanised steel.

Unpainted galvanised steel must not be used for roofing or rainwater goods including valleys and gutters to collect water run-off from ZINCALUME® steel products or any other inert material.

ZINCALUME® coated steel and COLORBOND® prepainted steel products can be used to collect water from galvanised or any inert catchment material.

These points are summarised in the diagrams below:

							
ROOF	ADDITION Compatibility	ROOF	GUTTER Compatibility	ROOF	ADDITION Compatibility	ROOF	GUTTER Compatibility
GALVANISED	ZINCALUME® COLORBOND® GLASS GLAZED TILES ALUMINIUM ACRYLIC FIBREGLASS PVC GALVANISED	GALVANISED	ZINCALUME® COLORBOND® PVC GALVANISED	ZINCALUME® COLORBOND® GLASS GLAZED TILES ALUMINIUM ACRYLIC FIBREGLASS PVC	ZINCALUME® COLORBOND® GLASS GLAZED TILES ALUMINIUM ACRYLIC FIBREGLASS PVC Incompatibility GALVANISED	ZINCALUME® COLORBOND® GLASS GLAZED TILES ALUMINIUM ACRYLIC FIBREGLASS PVC	ZINCALUME® COLORBOND® PVC Incompatibility GALVANISED

Design Guide:

1. On galvanised roofing, run skylights down to the gutter.
2. To achieve maximum life from your rainwater goods we recommend that they are manufactured from either ZINCALUME® steel or COLORBOND® prepainted steel products.
3. Unpainted galvanised steel must not be used for roofing or rainwater goods, including valleys and gutters, to collect water run-off from ZINCALUME® coated steel products or any other inert material.

HANDLING

General

New Zealand Steel Limited products are top quality and perform best when handled correctly.

- Don't handle them roughly or carelessly.
- Don't drag or slide new sheets over other products or rough surfaces.
- All equipment and materials taken on to the roof should be clean and care taken to prevent damaging the surface.

Use of Lifting Booms

- Long lengths of roofing are best lifted with the aid of a lifting boom.
- Lifting booms may be available from the profile manufacturer.
- Ensure loads are secure prior to lifting.

Footwear

- Anyone walking on the roof should wear flat rubber-soled footwear to prevent marking.
- Put an old mat or piece of carpet at the base of the ladder so that shoes can be cleaned before going up on the roof.
- Care should be taken walking on roofs as they may be slippery at times.



JOINING, SEALING AND LAP PRIMING

Soldering should only be used on unpainted galvanised steel (Not on COLORBOND® pre-painted steel or ZINCALUME® steel).

Use only neutral cure silicone rubber sealants.

Thoroughly clean off surplus sealant using a dry, lint-free cloth or plastic scraper.

Do not rely on sealants alone for joining. Mechanical fasteners (e.g. rivets, self-tapping screws etc.) should always be used as well.

End laps in profiled metal roofing should be avoided where possible. When unavoidable, the end lap of ZINCALUME® steel and painted profiles should be sealed with a double bead of sealant as in the illustration below.

Unpainted galvanised corrugate profile **end laps MUST** be primed on both overlapping surfaces with an appropriate paint system.

Edge laps on unpainted galvanised corrugate profiles **do not require lap priming**.

End or edge laps of unpainted ZINCALUME® steel **do not require lap priming**.

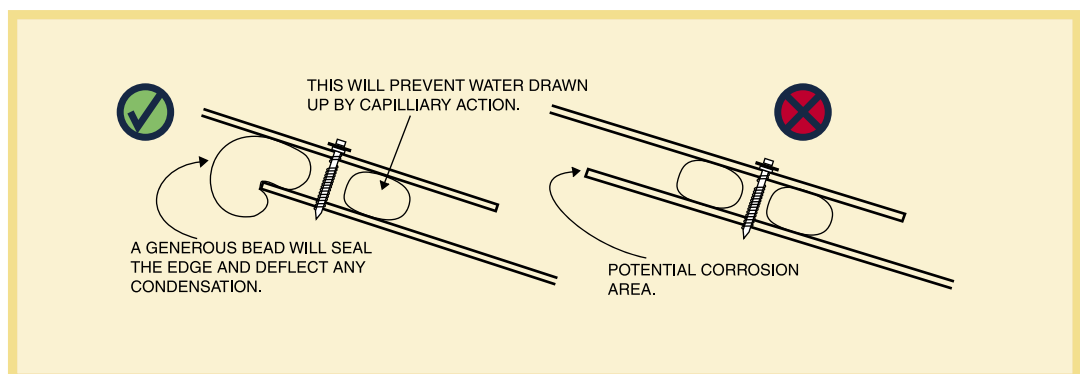



MAINTENANCE

All roofing and cladding products are subject to the cumulative effects of weather, dust and other deposits. Normal rain washing will remove most accumulated atmospheric contaminants from roofs. For wall cladding, manual washing every 3 to 12 months, depending on the paint system, is recommended in moderate to very severe environments to prevent accumulation of dirt, debris or other material not removed by rain washing. For areas that receive little or no rain washing (called unwashed areas) such as soffits, wall cladding under eaves, underside of gutters, fascias, sheltered areas of garage doors and unwashed roof areas, more extensive manual washing is required. Similarly, other High Risk areas, around flues, under television aerials or overhanging trees and sites prone to mould, lichen, bird droppings or debris, need to have regular manual washing.

Regular washing of COLORBOND® prepainted steel products increases the durability by reducing attack from airborne salts and pollutants. GALVSTEEL™ products and ZINCALUME® steel products will also benefit from routine washing.

COLORBOND® prepainted steel surfaces should be manually washed with water and a sponge or a soft nylon-bristled brush. For large areas it may be more appropriate to use water blasting at pressures up to 20MPa.

Overpainting of COLORBOND® prepainted steel products is discussed on Page 20 of this publication.

If New Zealand Steel Limited products are maintained according to the following recommendations, the requirements of the New Zealand Building Code B2 for 15 year durability for roofs and exterior walls will be met or exceeded.

Note:

- 1. The New Zealand Building Code durability requirement does not include aesthetic appearance.**
- 2. The New Zealand Building Code requires a durability of 15 years minimum (with maintenance) for roofing, including valleys, and wall cladding products. This means no moisture penetration due to product failure.**
- 3. The New Zealand Building Code requires a durability of 5 years minimum (with maintenance) for rainwater products, gutters and downpipes. This means no perforation due to product failure.**
- 4. New Zealand Steel Limited products are designed to exceed the New Zealand Building Code B2: durability requirements. Continued maintenance and overpainting will greatly extend the ultimate life of all products.**
- 5. In Industrial Environments, the type of pollution generated may alter the above recommendations. If in doubt, consult New Zealand Steel Limited.**

The maintenance information in the Environmental Chart is for guidance only.

Each proprietary building product should carry its own manufacturers' recommendations for usage.

New Zealand Steel Limited will not accept responsibility for proprietary roofing and cladding products which do not conform to our recommendations for manufacturing, environmental use or maintenance.



ROOFING & PROFILES (FIJI) LTD

info@roofingandprofiles.com.fj

www.roofingandprofiles.com.fj

MARKING, CUTTING AND DRILLING

- Black lead pencils must never be used for marking GALVSTEEL™, ZINCALUME® steel or COLORBOND® prepainted steel products. The carbon in the pencil promotes corrosion which will etch the surface of the material, leaving a permanent mark. Use a pencil of any colour other than black.
- Cut and drill COLORBOND® prepainted steel material with care to avoid marring the high quality finish.
- Use nibblers or hand shears instead of a friction blade. A friction blade will damage both the metallic coating and the COLORBOND® prepainted steel surface. It will also generate hot swarf which will become imbedded in the paint surface.

All debris must be swept off the job at the end of each day.

Prevention of swarf damage is far easier than its cure.

MIXING OF BRANDS

Where different brands of prepainted material are used on the same building, differences in colour, gloss and weathering performance may appear obvious within a short period of time. This will be due to the different paint formulations used by different manufacturers.

New Zealand Steel Limited will not accept liability for problems caused by the mixing of brands or for post painted roofs.

When material is delivered to the site, inspect deliveries to ensure the correct brand and product type has been supplied.

Ensure that COLORBOND® products with widely differing production dates are not mixed in any contract.

Note: COLORBOND® is clearly branded on the reverse side to assist identification.

Design Guide:

1. Specify either COLORBOND® ULTRA™, COLORBOND® XRW™, COLORCLAD™ or COLORSTEEL® ENDURA™.

MIXING PRODUCTS ON A ROOF

Unpainted galvanised and ZINCALUME® steel products are fully compatible in direct contact or side-by-side, however, care should be taken when mixing on a roof for the following reasons:

- Early corrosion may occur because of the inert catchment effect. (Refer to page 15).
- Galvanised material is less durable than ZINCALUME® steel and therefore would weather more rapidly.
- When combined on a roof, galvanised steel and ZINCALUME® steel have a markedly different appearance.



ROOFING & PROFILES (FIJI) LTD
info@roofingandprofiles.com.fj
www.roofingandprofiles.com.fj

OVERPAINTING OF COLORBOND® PREPAINTED STEEL PRODUCTS

COLORBOND® prepainted steel products are designed for durability. However, all paint coatings will deteriorate over time. Therefore, at some stage, it will be necessary to repaint to avoid serious deterioration of the product.

The main consideration is the paint coating integrity to perform a suitable bond for the overpainted system so that the durability of the new coating system is maintained.

New Zealand Steel's experience would indicate that this period to first repaint is around 15 years. However, local climatic conditions, building design and paint colour can have a significant influence on the performance of the paint system. Therefore you may need to consult New Zealand Steel or our paint suppliers, Akzo Nobel Coatings Ltd, Ameron (NZ) Ltd or PPG Industries NZ Ltd to help assess the most suitable time to repaint.

COLORBOND® prepainted steel products may be readily overpainted, after suitable preparation, for aesthetic reasons. Detailed information is available in the New Zealand Steel Limited Information Brochure: Overpainting New and Weathered Steel Roofing.

PROCESSING PLANTS

Some commercial applications may create internal environments in which the build-up of pollutants or fumes are a potential source of corrosion. Plants where chlorine vapours are released should have adequate ventilation to minimise the risks.

Design Guide:

1. Where pollutants or humidity levels are likely to be high, allow for frequent air changes.
2. Passive ventilation may be inadequate to cope with the problem and the installation of fan systems should be considered and incorporated at the design stage.
3. Contact New Zealand Steel Limited for specialist advice.

PRODUCT SUITABILITY

In almost all applications, ZINCALUME® coated steel and COLORBOND® prepainted steel will out-perform galvanised steel. There are however, a small number of applications for which galvanised steel is more suitable.

ZINCALUME® coated steel and COLORBOND® prepainted steel products must not be used for:

- Formwork in contact with wet concrete.
- Products to be embedded in concrete. However, where very small volumes of concrete are involved (e.g. splashes) which are able to cure quickly, there is little corrosive effect.
- Fertiliser storage sheds and containers.
- Culverts, or where ZINCALUME® coated steel material is buried in the ground.
- Water tanks.
- Highly alkaline environments (e.g. cement manufacture).
- Coolroom products.
- Buildings for intensive animal farming.

In all of the above end use applications, Galvanised steel would be the recommended product.

PROFILE BEND DIAMETERS – ROOFING, WALL CLADDING AND ACCESSORIES

New Zealand Steel Limited products are custom designed to ensure maximum compatibility with the roll-forming process. The paint systems are designed to be durable and adhere to the metal substrate so that they are not affected by good roll-forming practices. However, tight tension bends in the finished product should be avoided as small cracks may be formed which expose the metal substrate to the atmosphere.

For optimum corrosion performance no visible microcracking should be present in the finished product. There are many factors, substrate, paint, bend diameter and forming practice, that affect the tendency to microcrack. Therefore, it is not practical to have a fixed bend diameter that guarantees no microcracking.

Most products, formed in well designed and operated equipment, will not have microcracks at tension bends. It is important that visual checks for microcracking be made on the finished product to ensure a high quality standard is maintained.

Products with microcracking on the tension bends will show earlier signs of corrosion when used in unwashed areas in severe environments.

Design Guide:

1. The use of corrugated profiles in severe and special conditions will help to ensure greater durability.

PROFILE DESIGN INFORMATION

Specifications relating to roofing and cladding profiles and pricing details should be sought from the specialist roofing manufacturers concerned. New Zealand Steel Limited does not provide a rollforming service.

Profile designs from your local supplier will specify the grade and BMT appropriate to any contract.

Definitions

1. BMT: Base metal thickness is the thickness of the uncoated steel core. The finished thickness of the material will increase by the accumulation of coatings during manufacture by New Zealand Steel Limited.
2. Grade: The mechanical strength of the steel substrate is expressed in yield strength values measured in MPa. Low strength steel may be rated as G1, G250 or G300. As the yield strength of the material increases, so do the values, so that G550 has the highest strength.
3. Span: The distance between purlins, as recommended by the Rollformer for each particular profile.

Specifying New Zealand Steel Limited roofing and cladding products

- Product (ZINCALUME®, COLORCLAD™, COLORSTEEL® ENDURA™, COLORBOND® XRW™, COLORBOND® ULTRA™)
- Profile
- Colour (Where applicable)
- BMT (e.g. 0.40 or 0.55mm)
- Grade (e.g. G300 or G550)

QUALITY ACCREDITATION

The New Zealand Steel Limited Paint Line received accreditation to ISO 9002 in April 1992 and has subsequently been upgraded to ISO 9001 since July 1993. An on-going programme of continuous improvement will ensure that practice at New Zealand Steel Limited continues to reflect the best available international technology.



ROOF PITCH REQUIREMENTS

Material	Pitch
For corrugated and low profile metal sheet	
Long-run steel	8°
End lapped steel	10°
For metal decking and trough sections	3°
Flat metal sheet (fully supported)	3°
Metal tile (long run)	10°
Metal tile (lapped)	12°

ROOFING & PROFILES (FIJI) LTD
info@roofingandprofiles.com.fj
www.roofingandprofiles.com.fj

! 🏠 ROOF FIXING FOR CYCLONE AREAS

The Danger Areas

The roof areas marked in yellow are subject to very high winds and must be given the following special attention.

It is recommended that STORM-TITE™ or BREMICK BRA, Class 4, Type 17 14 G x 65 Cyclonic fasteners as manufactured by Mechanical Plating Pty and Bremick Fasteners Ltd which comply with Australian Standard AS 3566, are used for roofing, cladding and associated accessories.

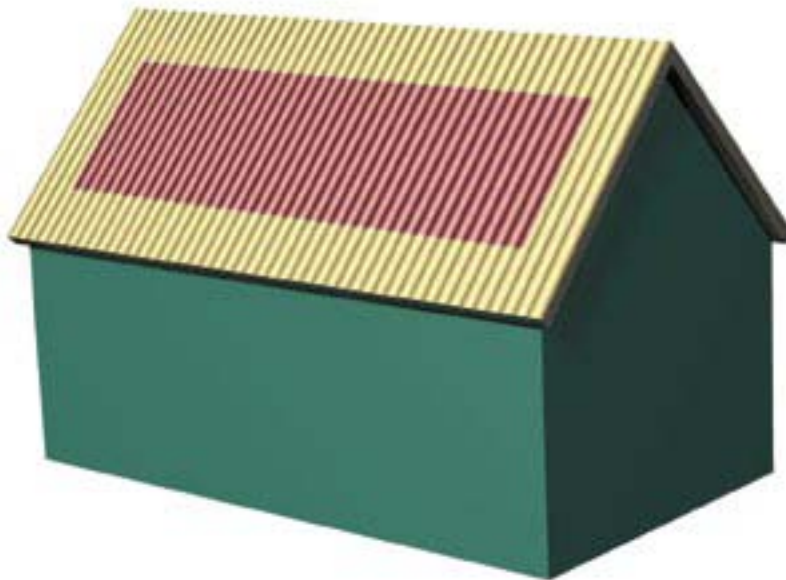

Cyclone Hex Head washer and 65mm self drilling screw

Installation

It is important that the maximum purlin spacing of 900mm is not exceeded, and that the roof overhang does not exceed 600mm. The timber framing of the roof should be dry before the roofing material is fixed.

Do not over-tighten the roofing screws or drive the nails too far. This will damage the washer and deform the roofing material.

Purlins

Purlins in the area marked yellow should be tied to the rafters with proprietary cyclone straps or galvanised wire.

Flashings

Flashings should always be used in the areas marked in yellow and careful attention must be given to the way they are fixed.

Flashings should be made from heavier gauge 0.55mm material and fixed on both faces as shown in the diagram.

Minimum depth of flashing should be 100mm.

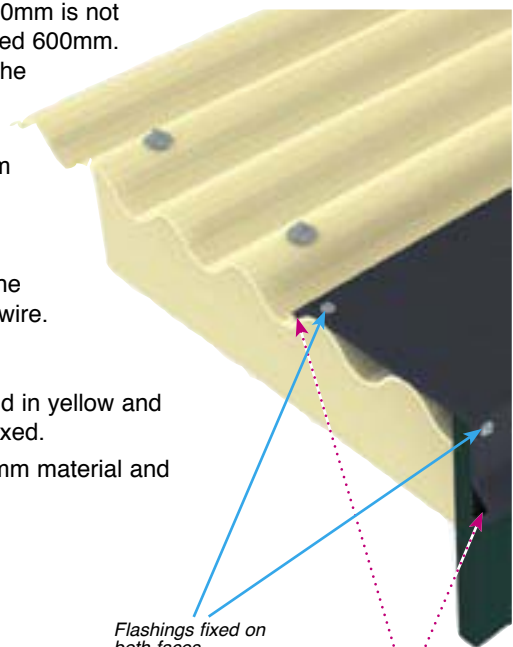

Flashings fixed on both faces

Ensure flashings have a stiffening fold on both edges



RECOMMENDED FASTENER SELECTION FOR CYCLONE AREAS

Fastener Selection – Cladding to Batten – Cyclonic Areas

Note: Fixing to supports thinner than 1.0mm may be with the screws listed for 1.0 - 2.5mm steel or with Type 17 screws of the same size. All fasteners exposed directly to the weather should be fitted with sealing washers.

Profile		Fixing to Steel		Fixing to Timber	
		1.0 – 2.5mm thick	2.5 – 5.0mm thick	Hardwood J1 – J3	Softwood J4
CUSTOM ORB CUSTOM BLUE ORB	Crest fixed	No.14 – 10 x 42mm Hex Head self drilling tapping screw	No.14 – 20 x 45mm Hex Head self drilling tapping screw	No.14 – 10 x 50mm Hex Head Type 17 self drilling screw	No.14 – 10 x 65mm Hex Head Type 17 self drilling screw
TRIMDEK SPANDEK		No.14 – 10 x 50mm Hex Head self drilling tapping screw	No.14 – 20 x 50mm Hex Head self drilling tapping screw	No.14 – 10 x 65mm Hex Head Type 17 self drilling screw	No.14 – 10 x 75mm Hex Head Type 17 self drilling screw
KLIP-LOK 700	Clip fixed	No.12 – 14 x 20mm Hex Head self drilling tapping screw	No.12 – 14 x 20mm Hex Head self drilling tapping screw	Type 17 self drilling wood screw hex head Softwood 12 – 11 x 40 Hardwood 12 – 11 x 25	
CUSTOM ORB CUSTOM BLUE ORB TRIMDEK SPANDEK	Valley fixed on wall	No.14 – 10 x 20mm Hex Head self drilling tapping screw	No.14 – 20 x 22mm Hex Head self drilling tapping screw	No.14 – 10 x 25mm Hex Head Type 17 self drilling screw	No.14 – 10 x 50mm Hex Head Type 17 self drilling screw

Fastening to Supports: Cyclonic Areas

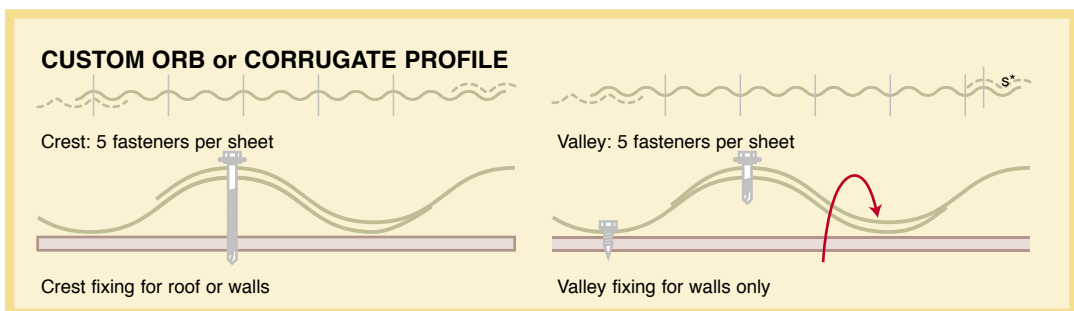
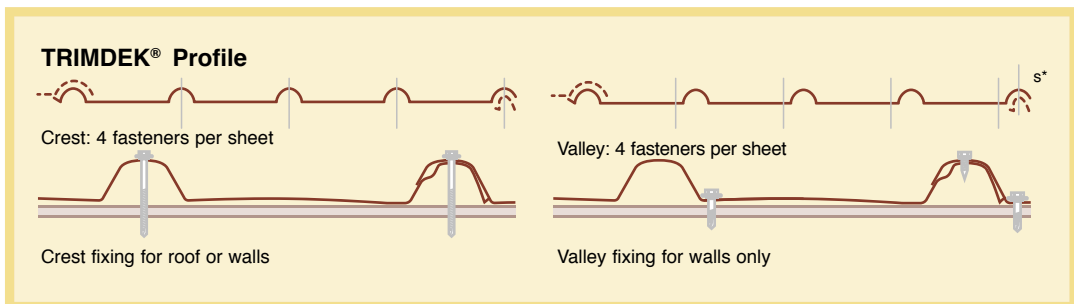
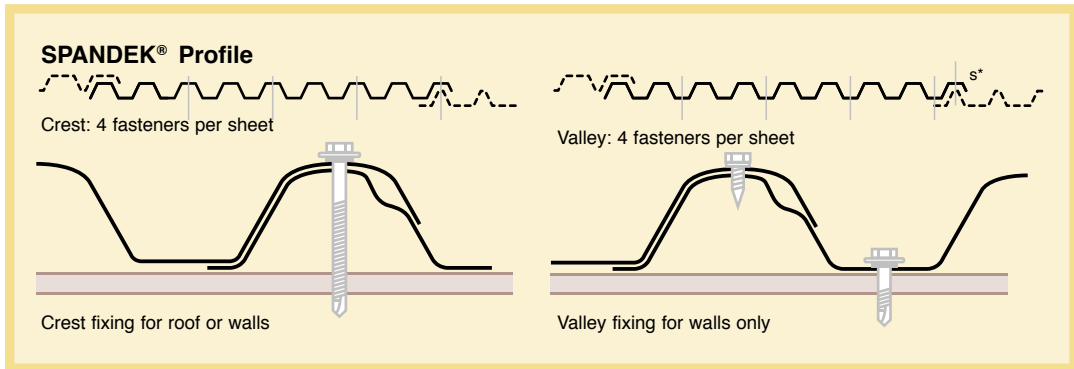

ROOFING & PROFILES (FIJI) LTD
 * Side lap
info@roofingandprofiles.com.fj
www.roofingandprofiles.com.fj

■ ■ SOLAR HEATING PANELS OR RUBBER MATS

During the installation of solar heating systems, care should be taken to prevent any damage to the roofing material. Because of the high temperatures created and the increased condensation which may result, care should be taken to maintain an air space between the roof and the heating unit. Follow manufacturers' recommendations concerning tube direction and the use of fixing support brackets.

Failure to do this may invalidate a COLORBOND® prepainted steel product warranty.

Design Guide:

1. Never place heating elements or plumbing units directly on the roof surface. Follow the system supplier's recommendations concerning installation.

■ STORAGE

Before it goes up on a roof, COLORBOND® prepainted steel, ZINCALUME® steel and GALVSTEEL™ products can be ruined by poor storage practices.

Follow these simple guidelines to help give optimum performance.

- On arrival, ensure the steel sheets are dry. If wet, open the pack immediately and separate the sheets to allow them to dry.
- Store packs of the material off the ground in a sheltered position.
- Cover packs with a loose fitting tarpaulin, allowing air to circulate.
- Provide some fall to drain water.
- Cross stacking of sheets allows air to circulate to help keep material in prime condition.
- Use only dry, untreated timber fillets for block stacking.
- Contact with wet concrete should be avoided.

Note: Failure to follow these handling and storage precautions could result in spoiling the surface appearance of the products and severely reducing their service life. On GALVSTEEL™ material this will appear as a white corrosion product (white rust), whereas on ZINCALUME® steel the corrosion product is black. This should not be confused with fretting. On COLORBOND® prepainted steel, the result of wet storage damage could be a bubbling of the paint surface.

Damage resulting from such failure invalidates the warranty and is not recoverable from New Zealand Steel Limited.

*Correct storage of
COLORBOND®
prepainted steel,
ZINCALUME® steel and
GALVSTEEL™ material, will
help give optimum
performance.*



ROOFING & PROFILES (FIJI) LTD
info@roofingandprofiles.com.fj
www.roofingandprofiles.com.fj



SWARF STAINING OF STEEL ROOFING AND CLADDING

Introduction

Swarf is the term given to the steel debris arising from cutting or piercing operations when using friction saws, drills etc., on steel roofing and cladding products. The use of abrasive discs is not recommended. Whilst comprising mostly fine steel particles, in this context swarf may also be taken to include any other discarded steel objects such as rivet shanks, nails, screws and nuts, which may come into contact with coated products; i.e: COLORBOND® prepainted steel, ZINCALUME® coated steel and galvanised steel.

Swarf particles, if left on the surface, will corrode and cause rust stains which will detract from the finished appearance of a project. These stains are often mistaken for early deterioration of the roofing and cladding itself.

Prevention of swarf staining is the responsibility of the installer and it is strongly suggested that the recommendations contained in this brochure be followed.

Generally, swarf particles come in contact with coated steel sheet products in three ways:

1. Loose particles left after cutting, drilling and riveting operations.
2. Hot swarf particles from disc cutting or drilling operations which may adhere to the finished surface.
3. Loose particles which may be trodden in or become embedded in the surface film of prepainted products under pressure from adjacent equipment or materials.

Prevention

Cutting

- Power shears or hand snips produce the least amount of debris.
- Power nibblers give a clean cut but generate debris which if left is prone to corrosion.
- Metal friction blades produce fine hot particles which can imbed easily into the coating surface and corrode rapidly.

If there is no alternative but to cut with a friction blade, the sheet should be cut away from the job and any other sheets. Where this is not practical, newly fixed roofing should be masked off with building paper or similar material to allow for the collection and disposal of any swarf particles. The sheet should be cut with the top surface downward to minimise top damage. Hand shears should be used to trim back any ragged edges.

Drilling

The area around the hole should be masked to shield the product from hot swarf.

Installation

Smooth soled shoes should be worn when working on a roof; avoid the ribbed type which will carry swarf and other objects.

Clean up

Swarf should be swept or hosed from the job progressively, and certainly at the end of each day. This action will remove loose particles. Maximum care should be taken when attempting to detach swarf which has become stuck. This can be done, but no action which is likely to remove the paint or metal coatings should be attempted. Any damage to these coatings will lead to reduced life of the material.

When sweeping or hosing into a gutter, clean out the gutter before leaving the job in order to prevent premature corrosion. On completion of the job, give a final wash or sweep down.

For critical applications, inspection of the job should be made after two weeks when rain or condensation will have caused any remaining swarf to rust, and will highlight affected areas. TREAT AS FOR REPAIR.

Note: Many swarf staining problems arise not from installers, but from other contractors working in the vicinity. Architects and builders need to be aware of this possibility, and warn contractors accordingly.

Identification

Fresh swarf stains are characterised by small red-brown coloured areas with a central dark spot (the remains of the steel particles). The surface will feel like sandpaper, and the particle may be lifted with a fingernail.

An old swarf stain will appear as a localised red-brown stain, the steel particle having corroded away, and the surface will be smoother.

Effect on Performance

The effect of swarf staining itself on COLORBOND® prepainted steel products, is generally aesthetic and may not be detrimental to the performance of the product. The product life will, however, be severely affected where attached swarf particles have penetrated the prefinished film and are in contact with the protective metallic coating, although this only occurs in severe cases. This is because, on prepainted surfaces, red oxides of iron are insoluble in water, and the stain will take considerable time to weather away.

On metallic coatings, concentrated corrosion can occur over a small area as the zinc in the coating sacrifices itself to prevent oxidation of both the swarf and, if allowed to continue, exposed areas of the steel base. Removal of swarf in the first place is far superior to repair of damage.

Repair

Metallic-Coated Steel Sheet

Brush the surface with a stiff bristle (not metallic wire) brush to dislodge particles which must then be completely removed, not just swept into the guttering. Wire brushing will mar the appearance of the sheet if brushing is not followed by painting. If the coating is severely damaged by swarf corrosion, the area should be painted.

STEELWOOL MUST NOT BE USED as it breaks up and becomes swarf itself. It will also damage the paint surface.

It is the responsibility of the installer to rectify swarf stains. New Zealand Steel Limited cannot be held responsible for remedial action outside their control. No cure will restore the surface to its original condition. However, damage can be reduced by prompt action.

Mild Staining

A household cream cleanser, used according to directions, will remove most mild swarf stains. Take great care to remove the stain only and not to cause damage to the paint film. Minimise the cleaning of unaffected material.



Severe or Extensive Staining

In these cases, where aesthetic factors are important, such as on COLORBOND® prepainted steel finishes, overpainting may be the quickest solution.

The whole visible area should be repainted, as air drying paints will weather more rapidly, and in a different manner to prepainted roofing and cladding products.

If swarf particles are painted over, rust bleedthrough is likely to occur. These particles should be removed (see above).

UNWASHED AREAS

When contaminants such as windblown salt and dust accumulate on painted surfaces and become damp, corrosion will take place. Many windblown contaminants absorb moisture when exposed to high humidity and their presence on steel accelerates corrosion.

For this reason, areas on a building which are seldom washed by rain are particularly prone to early breakdown of the material.

This effect may first be noticed as a white corrosion product, typically seen on the underside of gutters, canopies, roof vents or on sheltered areas and the underside of profiles used horizontally as wall cladding. It will be more noticeable where tighter radius bends have been used in roll forming.

Even on coated steel where corrosion reactions are much slower, the presence of contaminants over long periods of time will increase the rate of corrosion.

When the underside of ZINCALUME® steel and COLORBOND® prepainted steel products are exposed in an unwashed area, e.g. canopies, verandas, eaves, lean to buildings etc., additional maintenance, above that specified on page 5, is required to ensure satisfactory performance of the product.

Design Guide:

1. Ensure **no** exposed eaves are incorporated into the design of a building, regardless of its position from the sea.
2. Warranties will **not** be issued by New Zealand Steel Limited where exposed eaves are present or designed into any residence or building.
3. Where unwashed areas cannot be designed out, specify regular washing of these areas as part of an ongoing maintenance programme. Refer to page 5 for New Zealand Steel Limited recommendations.
4. Design consideration for easy access must be given to areas that require regular maintenance.
5. Ensure profile bends are not tighter than those recommended under the heading of “Profile Bend Diameters – Roofing, Wall Cladding and Accessories”, and that there are no microcracks in the finished product.

UV PROTECTION

The South Pacific experiences some of the most extreme UV conditions in the world. UV light can cause breakdown of the resin used in some paints. This leads to erosion and chalking of the paint film. UV light can also cause the breakdown of pigments (particularly organic based pigments) resulting in fading.

In response to this threat, an on-going programme of product improvement has led to the formulation of the current COLORBOND® prepainted steel paint systems. These systems utilise pigments and resins which have been selected for their colour stability, flexibility and durability.



WATER PONDING

Where the roof pitch is low, changes in roof loadings may result in a negative pitch and consequently lead to water ponding. Water ponding is detrimental to the performance of COLORBOND® prepainted steel products. The following conditions commonly cause water ponding:

- Over-spaced purlins.
- Deformation of timber purlins.
- Placement of external loads such as air conditioning units.
- Rigid fixing on long spans which causes deformation of the profile as a result of thermal expansion.

Design Guide:

1. Never use a pitch of less than 3 degrees. Pitches of less than 3 degrees invalidate the warranty.
2. Design the roof according to the profile manufacturer's specifications.
3. On minimum pitch roofs, ensure that the gutter end of profiled sheets is turned down.
4. Allow for thermal expansion to prevent profile distortion.
5. Consider the use of walkways to prevent damage where the roof may be subject to heavy foot traffic.
6. Ensure roof penetrations do not block the flow of water from the roof.



WEATHERING OF COLORBOND® PRODUCTS

All building products will weather over time. The weathering of COLORBOND® prepainted steel products will result in changes to gloss and colour. Factors which influence the change are environmental pollution, UV levels, building orientation and paint colour.

Design Guide:

1. When adding to an existing building, consideration should be given to the weathered appearance of the COLORBOND® prepainted steel products in the older part of the building.

ROOFING & PROFILES (FIJI) LTD
info@roofingandprofiles.com.fj
www.roofingandprofiles.com.fj

FURTHER INFORMATION

For additional information, literature or technical assistance, please contact:

Pacific Export Sales
 New Zealand Steel Limited
 Private Bag 92 121, Auckland 1142
 Telephone: 0-9-375 8999
 Facsimile: 0-9-375 8213
 Email Address: nzexport@bluescopesteel.com
 http://www.colorsteel.co.nz

Colorbond®

COLORBOND® is a registered trademark of BlueScope Steel Limited.

Colorbond Ultra™

COLOUR FOR THE EXTREME

ULTRA™ is a trademark of BlueScope Steel Limited.

Colorbond® XRW™

PROVEN COLOURS OF THE PACIFIC

XRW™ is a trademark of BlueScope Steel Limited.

COLORCLAD™

COLORCLAD™ is a trademark of New Zealand Steel Limited.

COLORSTEEL® Endura™

ENDURA™ is a trademark of New Zealand Steel Limited.

COLORSTEEL®

COLORSTEEL® is a registered trademark of New Zealand Steel Limited.

Zincalume®

ZINCALUME® is a registered trademark of BlueScope Steel Limited.

GALVSTEEL™

GALVSTEEL™ is a trademark of New Zealand Steel Limited.

NOTE: With New Zealand Steel Limited's commitment to continuous improvement, information provided in this publication may be subject to modification. At the time of publication we believe the information contained in this document is the best available. Nonetheless, we reserve the right to modify any product, technique, equipment or statement to reflect improvements in the manufacture and application of coil coated products. The information is supplied without prejudice to New Zealand Steel Limited's standard terms and conditions of sale. In the event of any conflict between this information and the standard terms and conditions, the standard terms and conditions shall prevail.

This edition of the New Zealand Steel Specification and Installation Guide supersedes all previous editions.

Copyright© 2011 New Zealand Steel Limited.

NEW ZEALAND STEEL
 100% RECYCLABLE



Kiwi to the core



New Zealand Steel Limited, Private Bag 92 121, Auckland 1142, New Zealand. Ph 0-9-375 8999 Fax 0-9-375 8213

ROOFING & PROFILES (FIJI) LTD
 info@roofingandprofiles.com.fj
 www.roofingandprofiles.com.fj